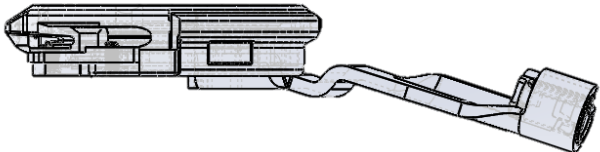
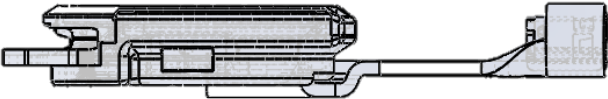
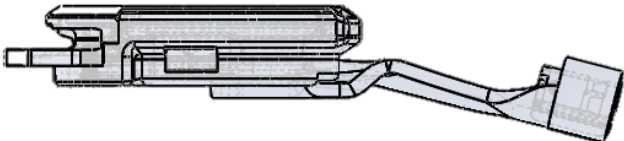

Shimano Cassette Joints: XMN+2.7

Gates Carbon Drive has just released two new rear sprockets for Shimano Alfine and Nexus hubs, part numbers CT1122XMN+2.7 and CT1124XMN+2.7. These sprockets move the belt line further outboard, allowing for easier integration with mid-drive eBike motors.

When using these new sprockets, it may be necessary to increase the clearance between the shifter cable and the rear sprocket. Shimano has released new special cassette joints for this purpose.

Bicycle assemblers need to check clearances between cassette joints and bicycle frame/components, to verify if the new special cassette joint is required. Contact Shimano for part numbers to the proper small parts kit.

	STANDARD CASSETTE JOINT	SPECIAL CASSETTE JOINT
Shimano Nexus 7 (CJNX10)		
Shimano Nexus 8 (CJ-8S20)		
Shimano Alfine 8 (SG-S7000-8)	